



A Series Walkie Straddle Stacker

with capacities of 2,500 to 4,000lbs

The walkie straddle stacker of American version is a new generation of products that are developed specially for North American market. This series consists of three models, which integrate features of existing products and stackers of American version of the company, with universal, optimal, and weight-based design, and can meet demands of North American market on functions. The state-of-the-art AC driving control technology is applied for the truck, which offers advanced performance, comfortable operation, safety and reliability, and low operation and maintenance cost. The stacker is an ideal tool for loading, unloading, and handling palletized goods in warehouse, supermarket, and workshop.



Environment/ Efficiency/ Economy

Appearance

- / Stacker of American Version is completed with specialized industrial design of appearance. The entire truck features smooth lines and affluent sense of movement, with full consideration to ergonomics, in accord with the latest appearance design trend.
- / It is manufactured with a number of steel plate stamping and injection molding technologies, solid and durable, in compliance with environmental requirements.



High Performance

- / Standard configuration of EPS (Electric Power Steering) system of walkie straddle stacker offers easier and more flexible operation.
- / Stepless speed regulation for lifting and lowering is a standard configuration for full series of the stacker.
- / The AC travel motor features excellent acceleration performance, outstanding climbing ability, low heat emission, and is brushless, and maintenance-free.
- / The latest CURTIS AC control system realizes accurate and stable control, and higher efficiency.
- / The CANBUS bus structure makes communication of the entire truck faster and more reliable.
- / Regenerative brake of the truck prevents it from sliding on a slope.
- / Hydraulic power pack, switches, plug connectors, battery display, timer and other important parts are all of world-renowned brands.

Comfort

- / The tiller is simple but beautiful, and function buttons are comfortable for operation.
- / Truck structure of optimized design guarantees terrific view for the operator, and easy entering and withdrawing from pallet.
- / Compact truck body and large rounded corner design make the truck suitable for operation in narrow space, and wedge-shaped design of chassis increases passing ability significantly.
- / Battery side roll out can realize easy and fast replacement of battery (optional).

Reliability

- / Three-support-point and low-gravity-center design and the high-strength steel plate framed structure feature large residual load capacity, and long service life.
- / All wires and cables have reliable protection, which increases reliability of electrical system significantly.
- / Non-contact proximity switch features long service life and reliable operation.
- / The world-leading hydraulic power unit features low noise, small vibration, and stable and reliable rising and declining.
- / The mast is made of H-shaped steel channels, which offer better rigidity and stability in comparison with C-shaped steel channels.
- / Power plug is fastened to truck body, which can avoid damage of plug due to impact when battery is lifted for installation.
- / The structure of rotary load wheel offers the truck better passing ability.



The unique lighted creep speed driving function allows the truck to move at slow speed more conveniently



Distance between wheel arms: 38.2"



Standard configuration of lifting and lowering stepless speed regulation realizes more accurate operation of the fork



The structure of rotary load wheel offers the truck better passing ability



Standard specification

- / AC drive motor
- / CURTIS AC drive motor controller + oil pump motor controller
- / EPS system
- / Automatic deceleration at turns
- / Speed of lifting and lowering can all be regulated in proportion
- / Multi-function battery condition meter
- / Double high-performance load wheels
- / Fork length 42.1"
- / Adjustable outer distance of forks within the range of 8.3-31.1"
- / 106.3" duplex mast with double lifting cylinders
- / Mast intelligent declining buffer
- / Multi-function tiller
- / Speed limit when fork is at elevated location
- / Horn
- / Key switch
- / Creep speed function
- / Emergency reverse
- / Mast shield of wire mesh

Safety

- / As a standard configuration, speed is lowered automatically when fork is lifted to specified height.
- / The function of lowering speed automatically as steering angle increases is a standard configuration.
- / Three types of braking function - release braking, reverse braking, and emergency braking - can ensure safety of traveling.
- / Anti-sliding function on slope can ensure safety of operation.
- / The emergency reversing button at top of the tiller can avoid the driver from injury effectively in case of emergency during backward driving of the truck.
- / The function of intelligent declining buffer reduces lowering speed automatically when the fork is lowered to a height less than 3.9" from ground, which provides effective protection for goods.

Maintenance

- / The brushless, maintenance-free AC motor reduces operation cost significantly.
- / The meter integrating battery indicator, timer, and fault self-diagnosis is convenient for maintenance.
- / Design of open battery compartment allows easier replacement and maintenance of the battery.
- / Back cover can be opened fully, and all components and parts are clear at a glance, which is very convenient for maintenance of the entire truck.

Options

- / Various fork lengths
- / Load backrest (height 48")
- / Trolley wheels for battery side roll out
- / Sideshifter
- / Cold storage (-30 C)
- / Mast shield of PC plate
- / Mast of various heights



A Series Walkie Straddle Stacker Specification

Distinguishing marks	1.1	Manufacturer	HANGCHA GROUP CO.,LTD.			
			CTD11-AC1-NA	CTD14-AC1-NA	CTD18-AC1-NA	
Weights	1.2	Manufacturer's type designation	electric	electric	electric	
	1.3	Drive:electric(battery or mains),diesel,petrol,fuel gas	electric	electric	electric	
	1.4	Operator type:hand,pedestrian,standing,seated,order-picker	pedestrian	pedestrian	pedestrian	
	1.5	Rated capacity/rated load	1100/2500	1400/3000	1800/4000	
	1.6	Load centre distance	c(mm/in)	600/24	600/24	600/24
	1.8	Load distance, centre of drive axle to fork	x(mm/in)	567/22.3	546.5/21.5	546.5/21.5
	1.9	Wheelbase	y(mm/in)	1295/51.0	1405/55.3	1405/55.3
	2.1	Service Weight without battery	kg/lb	1080/2381	1118/2465	1143/2520
	Wheels, Chassis	3.1	Tyres:solid rubber,superelastic,pneumatic,polyurethane	PU	PU	PU
3.2		Tyre size, front	mm/in	Φ250×80	Φ250×80	Φ250×80
3.3		Tyre size, rear	mm/in	Φ100×70	Φ100×70	Φ100×70
3.5		Wheels, number front / rear (x = driven wheels)		1×/4	1×/4	1×/4
3.6		Tread, front	b11 (mm/in)	1065/41.9	1065/41.9	1065/41.9
4.2		Height,mast lowered	h1 (mm/in)	1887/74.3	1887/74.3	1992/78.4
Basic Dimensions	4.4	Lift	h3 (mm/in)	2700/106.3	2700/106.3	2700/106.3
	4.5	height, mast extended	h4 (mm/in)	3207/126.3	3207/126.3	3312/130.4
	4.9	Height of tiller in drive position min./max.	h24 (mm/in)	790/1480 (31.1/58.3)	790/1480 (31.1/58.3)	790/1480 (31.1/58.3)
	4.10	Height of wheel arms	h8 (mm/in)	130/5.1	130/5.1	130/5.1
	4.15	Height, lowered	h13 (mm/in)	50/2.0	50/2.0	60/2.4
	4.19	Overall length	l1 (mm/in)	2016 ¹⁾ /79.4 ¹⁾	2126 ¹⁾ /83.7 ¹⁾	2146 ¹⁾ /84.5 ¹⁾
	4.20	Length to face of forks	l2 (mm/in)	946 ¹⁾ /37.2 ¹⁾	1056 ¹⁾ /41.6 ¹⁾	1076 ¹⁾ /42.4 ¹⁾
	4.21	Overall width	b1/b2 (mm/in)	870/1170 (34.3/46)	870/1170 (34.3/46)	870/1170 (34.3/46)
	4.22	Fork dimensions	s/e/l (mm/in)	35/100/1070(1.4/3.9/42.1)	35/100/1070(1.4/3.9/42.1)	45/100/1070(1.8/3.9/42.1)
	4.24	Fork-carriage width	b3(mm/in)	825/32.5	825/32.5	825/32.5
	4.25	Distance between fork-arms	b5 (mm/in)	210~790 (8.3~31.1)	210~790 (8.3~31.1)	210~790 (8.3~31.1)
	4.26	Distance between wheel arms	b4 (mm/in)	970~1270 (38~50) ²⁾	970~1270 (38~50) ²⁾	970~1270 (38~50) ²⁾
	4.32	Ground clearance, centre of wheelbase	m2 (mm/in)	70/2.8	70/2.8	70/2.8
	4.35	Turning radius	Wα (mm/in)	1495/58.9	1605/63.2	1605/63.2
	4.37	Length across wheel arms	l7 (mm/in)	1640/64.6	1750/68.9	1750/68.9
		Battery compartment width	l6 (mm/in)	230/9.0	340/13.4	340/13.4
		Battery compartment length	b6 (mm/in)	817/32.2	817/32.2	817/32.2
		Battery floor Height w/optional rollers	mm/in	240/9.4	240/9.4	240/9.4
		Grade clearance	D(%)	39.8	39.8	39.8
	Top vertical braking Arc	Q(°)	15	15	15	
	Bottom braking Arc	M(°)	10	10	10	
	Handle Operating Arc	S(°)	65	65	65	
Performance Data	5.1	Travel speed, laden/unladen	kph(mph)	5.5/5.5(3.4/3.4)	5.5/5.5(3.4/3.4)	5.5/5.5(3.4/3.4)
	5.2	Lift speed, laden/unladen	m/s(ft/min)	0.090/0.195(1.7/38.39)	0.133/0.243(26.18/47.83)	0.127/0.214(25.42/13)
	5.3	Lowering speed, laden/unladen	m/s(ft/min)	0.290/0.360(5.70/70.87)	0.295/0.350(58.07/68.90)	0.200/0.240(39.37/47.24)
	5.8	Max.gradeability, laden/unladen	%	8/16	7/14	6/14
	5.10	service brake		Electromagnetic braking	Electromagnetic braking	Electromagnetic braking
Electric-motor	6.1	Drive motor rating S2 60 min.	kW/hp	1.5/2.0	1.5/2.0	1.5/2.0
	6.2	Lift motor rating at S3 15%	kW/hp	2.2/2.95	3.2/4.29	3.2/4.29
	6.4	Battery voltage/nominal capacity K5	V/Ah	24/240	24/300	24/300
		Minimum battery weight	kg/lb	120/265	150/330	150/330
	Maximum battery weight	kg/lb	300/660	500/1102	500/1102	
Others	8.1	Type of drive control		AC CURTIS	AC CURTIS	AC CURTIS
	10.5	Steering design		Electronic steering	Electronic steering	Electronic steering
	10.7	sound pressure level at the driver's seat	dB(A)	70	70	70

Note:1) Triplex mast +21mm(0.83in)

2) 50mm(2in) increments

Specifications are subject to change without notice.

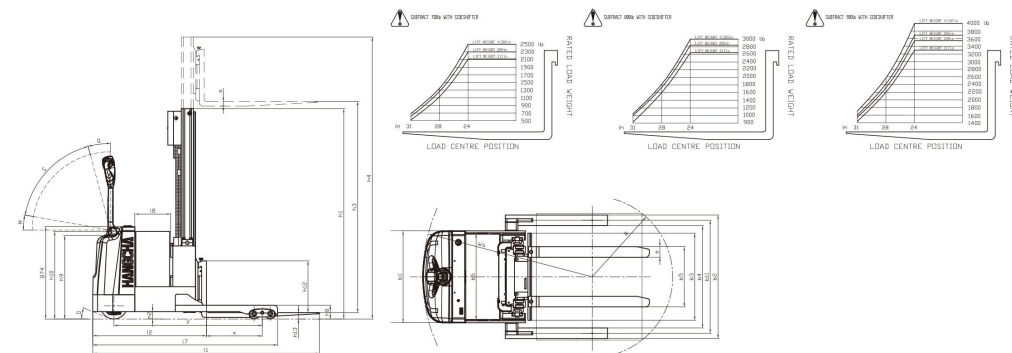

Mast Specification

Type	Fork lift height h ₃		Max. fork height (h ₃ +h ₁₃)		Mast lowered h ₁		Mast extended h ₄		Free lift		Capacity Load capacity at 600mm/24in			
	mm	in	mm	in	mm	in	mm	in	mm	in	CTD11-AC1-NA		CTD14-AC1-NA	
	mm	in	mm	in	mm	in	mm	in	mm	in	kg	lb	kg	lb
Wide view mast	2000	78.7	2050	80.7	1537	60.5	2507	98.7	110	4.3	1134	2500	1361	3000
	2500	98.4	2550	100.4	1787	70.4	3007	118.4	110	4.3	1134	2500	1361	3000
	2700	106.3	2750	108.3	1887	74.3	3207	126.3	110	4.3	1134	2500	1361	3000
	3000	118.1	3050	120.1	2037	80.2	3507	138.1	110	4.3	1134	2500	1361	3000
	3300	129.9	3350	131.9	2187	86.1	3807	149.9	110	4.3	1134	2500	1361	3000
	3500	137.8	3550	139.8	2237	88.1	4007	157.8	110	4.3	1134	2500	1361	3000
	3600	141.7	3650	143.7	2337	92.0	4107	161.7	110	4.3	1134	2500	1361	3000
	3700	145.7	3750	147.6	2387	94.0	4207	165.6	110	4.3	1134	2500	1361	3000
	3800	149.6	3850	151.6	2437	95.9	4307	169.6	110	4.3	1134	2500	1361	3000
	4000	157.5	4050	159.4	2637	103.8	4607	181.4	110	4.3	1134	2500	1361	3000
Wide view full free duplex mast	2000	78.7	2050	80.7	1595	62.8	2595	102.2	1050	41.3	1134	2500	1361	3000
	2500	98.4	2550	100.4	1845	72.6	3095	121.9	1300	51.2	1134	2500	1361	3000
	2700	106.3	2750	108.3	1945	76.6	3295	129.7	1400	55.1	1134	2500	1361	3000
	3000	118.1	3050	120.1	2095	82.5	3595	141.5	1550	61.0	1134	2500	1361	3000
	3300	129.9	3350	131.9	2245	88.4	3895	153.3	1700	66.9	1134	2500	1361	3000
	3500	137.8	3550	139.8	2345	92.3	4095	161.2	1800	70.9	1134	2500	1361	3000
	3600	141.7	3650	143.7	2395	94.3	4195	165.2	1850	72.8	1134	2500	1361	3000
	3700	145.7	3750	147.6	2445	96.3	4295	169.2	1900	74.7	1134	2500	1361	3000
	4000	157.5	4050	159.4	2645	104.2	4695	185.0	2100	80.6	1134	2500	1361	3000
	Wide view full free triplex mast	3500	137.8	3550	139.8	1844	72.6	4214	165.9	1180	46.5	1134	2500	1361
3700		145.7	3750	147.6	1909	75.2	4409	173.6	1240	48.8	1134	2500	1361	3000
4000		157.5	4050	159.4	2009	79.1	4709	185.4	1340	52.8	1134	2500	1361	3000
4300		169.3	4350	171.3	2109	83.0	5009	197.2	1440	56.7	1134	2500	1361	3000
4500		177.2	4550	179.1	2159	85.0	5159	203.1	1540	60.6	1134	2500	1361	3000
4700		185.0	4750	187.0	2259	88.9	5459	214.9	1540	60.6	1134	2500	1361	3000
5000		196.9	5050	198.8	2354	92.7	5744	226.1	1760	69.3	1134	2500	1361	3000
5200		204.7	5250	206.7	2409	94.8	5909	232.6	1740	68.5	1134	2500	1361	3000
5500		216.5	5550	218.5	2509	98.8	6209	244.4	1850	72.8	962	2120	1202	2650

Mast Specification

Type	Fork lift height h ₃		Max. fork height (h ₃ +h ₁₃)		Mast lowered h ₁		Mast extended h ₄		Free lift		Capacity Load capacity at 600mm/24in	
	mm	in	mm	in	mm	in	mm	in	mm	in	CTD18-AC1-NA	
	mm	in	mm	in	mm	in	mm	in	mm	in	kg	lb
Wide view mast	2000	78.7	2060	81.1	1642	64.6	3612	142.2	120	4.7	1814	4000
	2500	98.4	2560	100.8	1892	74.5	3112	122.5	120	4.7	1814	4000
	2700	106.3	2760	108.7	1992	78.4	3312	130.4	120	4.7	1814	4000
	3000	118.1	3060	120.5	2142	84.3	3612	142.2	120	4.7	1814	4000
	3300	129.9	3360	132.3	2292	90.2	3912	154.0	120	4.7	1814	4000
	3500	137.8	3560	140.2	2392	94.2	4112	161.9	120	4.7	1814	4000
	3600	141.7	3660	144.1	2442	96.1	4212	165.8	120	4.7	1814	4000
	3700	145.7	3760	148.0	2492	98.1	4312	169.8	120	4.7	1814	4000
	3800	149.6	3860	152.0	2542	100.1	4412	173.7	120	4.7	1814	4000
	4000	157.5	4060	159.8	2742	108.0	4712	185.5	120	4.7	1814	4000
Wide view full free duplex mast	4300	169.3	4360	171.7	2892	113.9	5012	197.3	120	4.7	1814	4000
	4500	177.2	4560	179.5	2992	117.8	5212	205.2	120	4.7	1814	4000
	2000	78.7	2060	81.1	1700	66.9	2700	106.3	1060	41.7	1814	4000
	2500	98.4	2560	100.8	1950	76.8	3200	126.0	1310	51.6	1814	4000
	2700	106.3	2760	108.7	2050	80.7	3400	133.9	1410	55.5	1814	4000
	3000	118.1	3060	120.5	2200	86.6	3700	145.7	1560	61.4	1814	4000
	3300	129.9	3360	132.3	2350	92.5	4000	157.5	1710	67.3	1814	4000
	3500	137.8	3560	140.2	2450	96.5	4200	165.4	1810	71.3	1814	4000
	3600	141.7	3660	144.1	2500	98.4	4300	169.3	1860	73.2	1814	4000
	Wide view full free triplex mast	3500	137.8	3560	140.2	1944	76.5	4314	169.8	1070	42.1	1814
3700		145.7	3760	148.0	2009	79.1	4509	177.5	1160	45.7	1814	4000
4000		157.5	4060	159.8	2109	83.0	4809	189.3	1260	49.6	1814	4000
4300		169.3	4360	171.7	2209	87.0	5109	201.1	1360	53.5	1814	4000
4500		177.2	4560	179.5	2259	88.9	5259	207.0	1460	57.5	1814	4000
4700		185.0	4760	187.4	2359	92.9	5559	218.9	1460	57.5	1814	4000
5000		196.9	5060	199.2	2454	96.6	5844	230.1	1570	61.8	1814	4000
5200		204.7	5260	207.1	2509	98.8	6009	236.6	1660	65.4	1678	3700
5500	216.5	5560	218.9	2609	102.7	6309	248.4	1760	69.3	1497	3300	