



XH SERIES HIGH-VOLTAGE LITHIUM BATTERY FORKLIFT

with capacity of 2,000 to 3,800kg



ZHEJIANG HANGCHA IMP. & EXP. CO., LTD.

Factory site: 666 Xiangfu Road, Hangzhou, Zhejiang, China (311305)

Tel: +86-571-88926735 88926755
Fax: +86-571-88926789 88132890

sales@hcforklift.com
www.hcforklift.com

			
Follow us on Facebook	Follow us on YouTube	Follow us on WeChat	Download "Hangcha Forklift" App
			HANGCHA trucks conform to the European Safety Requirements.
ISO14001:2015	ISO9001:2015		

2023 VERSION 2/COPYRIGHT 2023 /04

HANGCHA GROUP CO., LTD. reserves the right to make any changes without notice concerning colors, equipment, or specifications detailed in this brochure, or to discontinue individual models. The colors of trucks, delivered may differ slightly from those in brochures.

The World of Hangcha



VOLTAGE

309 V

100% CHARGE FOR

1 Hour

WATER RESISTANCE

IPX4

SPEED MODELS

3

PROTECTION RATE

IP67

THE *Plus*
FOR YOUR
BUSINESS



COMMITTED TO IMPROVING

FASTER & MORE EFFICIENT

Compared with low-voltage lithium battery forklifts, high-voltage lithium battery technology can save about 40% of the overall cost during the service cycle.

40%

Low Voltage Lithium Battery Forklift
Hangcha High Voltage Lithium Electric Forklift

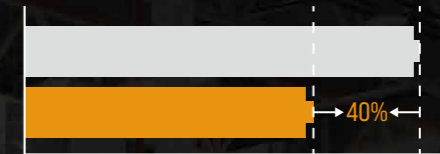

Compared with fuel forklifts, high-voltage lithium battery technology can save about 90% of the overall cost during the service cycle.

90%

Fuel Forklift
Lithium Electric Forklift

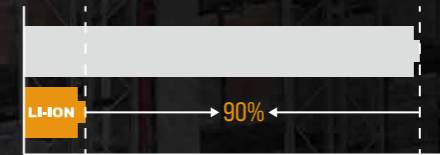

4000 CYCLES OF CHARGING



Under normal charging and discharging conditions, the lithium battery of Hangcha products has a capacity retention rate of more than 75% and a life span of up to 10 years after 4000 cycles of charging and discharging.

POWER PERFORMANCE COMPARISON

	High Voltage Lithium Electric Forklift	Fuel Forklift
Travel speed, laden/unladen	21/21.5km/h	15-20km/h
Lift speed, laden/unladen	435/500mm/s	430/470mm/s
Max. gradeability, S2=5min, laden/unladen	20%/25%	15%-20%

Through disruptive battery and fast charging technology, the charging time is greatly shortened.

Get the battery fully charge:



Hangcha High Voltage Electric Forklift



Electric Forklift

Fast charging makes it possible for the whole vehicle to work continuously, shortening the waiting time and greatly improving efficiency.

Battery capacity

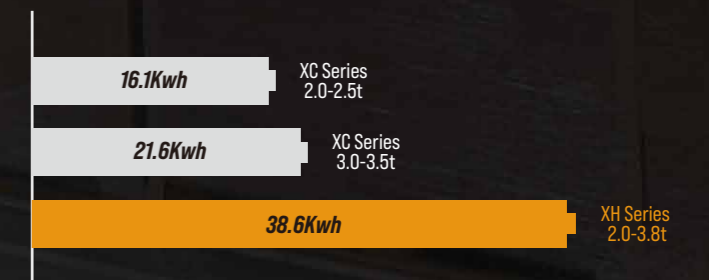

XH Series High-voltage Lithium Battery Forklift

Independently developed by Hangcha on the basis of decades of deep understanding of electric forklifts and internal combustion forklifts, the dedicated XH series high voltage lithium battery forklifts are a new series of electric counterweight forklifts with a new energy vehicle voltage platform and a pioneered special structure that represents a breakthrough over the traditional design concept. Representing a redefinition of electric forklifts in terms of efficiency, power, reliability, etc., this series of electric forklift models will supersede the internal combustion forklifts.



Exterior

/ With the inherited exterior design of the dedicated XC lithium battery forklift and a smooth and sturdy profile, the whole vehicle is impact, elegant, stylish, sturdy and powerful.



Maintainability

/ Equipped with a lock, the hood designed to be back-flipped open to and facilitate charging, liquid replenishment and maintenance.
/ The water tank lid can be removed quickly and easily without a tool to enable a large operating area for cleaning and maintenance.

Comfort

/ The wide-view mast with optimized design is unlikely to obstruct the operator's line of sight. The enlarged opening size of the fork carriage enables a wider view, a large operation space, and excellent ergonomic design.
/ The multifunctional color-screen instruments are designed to have graphical interfaces and display data clearly. Three speed gears are provided to adapt to different operating environments. The interfaces can be switched to be shown in Chinese and English to meet the needs of customers at home and abroad.
/ The enlarged brake pedal and appropriate regenerative braking function can effectively reduce the driver's fatigue.



Wide-view mast



Multifunctional color-screen instruments



INTELLIGENT. INTUITIVE. INNOVATIVE.



Advancement

- / Both the drive and operating systems are vehicle-grade permanent magnet synchronization systems, equipped with a high-speed ratio gearbox with a driving speed, upslope degree and acceleration performance rival that of internal combustion vehicles, and the environmental performance better than that of internal combustion vehicles.
- / The vehicle uses an overall controller, and the drive system and operating system are assembled with motors electronically controlled, to form a highly independent light, efficient, and intelligent drive system.
- / The vehicle's 309V high-voltage platform is equipped with a long-lasting large-capacity lithium battery, which is powerful, efficient and energy-saving, adopts a super-fast charging technology that enables a short charging time.
- / A water-cooling system with a good heat dissipation effect is used on a new energy forklift for the first time, so that the forklift can absolutely carry out long-time and high-intensity operations as internal combustion forklifts.



Safety

- / The cover of the vehicle is designed to be sealed to the water resistance level of IPX4. All the motor, electronic controls and high-voltage components reach the dust and water resistance level of IP67, a high protection level adequate to withstand harsh operating environments and ensure safety and reliability.
- / The electrical system is equipped with high-voltage interlocks, and insulation detection, insulation monitoring and vehicle-grade safety means. The MSD maintenance switch enables one-click power-down and safer maintenance.
- / The standard configuration provides electronic control functions for buffering the fork's descending and ascending to better protect goods.
- / The handbrake can be optionally equipped with an alarm buzzer to prompt the driver to pull up the handbrake before leaving the vehicle.
- / The optional descending lock function can disable the descending function when the driver leaves the seat and enable high safety.



XH Series High-voltage Lithium Battery Forklift Specification

Distinguishing mark	HANGCHA GROUP CO.,LTD.				
	1.1	1.2	1.3	1.4	1.5
1.1	Manufacturer				
1.2	Manufacturer's type designation	CPD20-XY2G-SI24	CPD25-XY2G-SI24	CPD30-XY2G-SI24	CPD35-XY2G-SI24
1.3	Drive: electric (battery or mains), diesel, petrol, fuel gas	Electric	Electric	Electric	Electric
1.4	Operator type: hand, pedestrian, standing, seated, order-picker	Seated	Seated	Seated	Seated
1.5	Rated capacity/rated load	Q (kg)	2000	2500	3000
1.6	Load centre distance	c (mm)	500	500	500
1.8	Load distance, centre of drive axle to fork	x (mm)	464	464	479
1.9	Wheelbase	y (mm)	1700	1700	1720
2.1	Service Weight	kg	3670	3900	4570
2.2	Axle loading, laden front/rear	kg	4930/740	5710/690	6620/950
2.3	Axle loading, unladen front/rear	kg	1785/1885	1780/2120	1915/2655
3.1	Tyres: solid rubber, superelastic, pneumatic, polyurethane		Pneumatic	Pneumatic	Pneumatic
3.2	Tyre size, front		7.00-12-12PR	7.00-12-12PR	28×9-15-14PR
3.3	Tyre size, rear		6.00-9-10PR	6.00-9-10PR	6.50-10-10PR
3.5	Wheels, number front / rear (x = driven wheels)		2x/2	2x/2	2x/2
3.6	Tread, front	b10(mm)	968	968	1005
3.7	Tread, rear	b11(mm)	975	975	975
4.1	Tilt of mast/fork carriage forward/backward	$\alpha/\beta(^{\circ})$	6/12	6/12	6/12
4.2	Height, mast lowered	h1(mm)	1998	1998	2165
4.3	Free lift	h2(mm)	140	140	145
4.4	Lift	h3(mm)	3000	3000	3000
4.5	Height, mast extended	h4(mm)	3970	3970	4065
4.7	Height of overhead guard (cabin)	h6(mm)	2165	2165	2167
4.8	Seat height/stand height	h7(mm)	1165	1165	1167
4.12	Coupling height	h10(mm)	503	503	505
4.19	Overall length	l1(mm)	3605	3605	3715
4.20	Length to face of forks	l2(mm)	2535	2535	2645
4.21	Overall width	b1(mm)	1195	1195	1225
4.22	Fork dimensions	s/e/l (mm)	40/122/1070	40/122/1070	45/122/1070
4.24	Fork-carriage width	bs(mm)	1038	1038	1100
4.25	Distance between fork-arms	bs(mm)	226/1008	226/1008	290/1100
4.31	Ground clearance, laden, below mast	m1(mm)	118	118	135
4.32	Ground clearance, centre of wheelbase	m2(mm)	137	137	139
4.34.1	Aisle width for pallets 1000 x 1200 crossways	Ast1(mm)	4024	4024	4099
4.34.2	Aisle width for pallets 800 x 1200 lengthways	Ast2(mm)	3824	3824	3904
4.35	Turning radius	Wa(mm)	2360	2360	2420
5.1	Travel speed, laden/unladen	km/h	21/21.5	21/21.5	21/21.5
5.2	Lift speed, laden/unladen	m/s	0.62/0.66	0.62/0.66	0.445/0.5
5.3	Lowering speed, laden/unladen	m/s	0.41/0.42	0.41/0.42	0.41/0.42
5.6	Max. Drawbar pull, laden/unladen	N	19000	19000	19000
5.8	Max. gradeability, laden/unladen	%	25/25	25/25	20/25
5.10	Service brake		Hydraulic	Hydraulic	Hydraulic
	Parking brake		Mechanical	Mechanical	Mechanical
6.1	Drive motor rating S2 60 min	kW	20AC	20AC	20AC
6.2	Lift motor rating at S3 15%	kW	24AC	24AC	24AC
6.4	Battery voltage, nominal capacity K5	V/Ah	309/125	309/125	309/125
6.5	Battery weight	kg	395	395	395
	Battery dimensions	l/b/h(mm)	1144/723/414	1144/723/414	1144/723/414
	Max. battery weight	kg	395	395	395
	Min. battery weight	kg	470	470	470
8.1	Type of drive unit		AC	AC	AC
9.1	Manufacturer/Type		Enpower/MC3902	Enpower/MC3902	Enpower/MC3902
10.1	Operating pressure for attachments	bar	185	185	185
10.8	Towing coupling, type DIN 15170		Φ 25 Pin	Φ 25 Pin	Φ 30 Pin

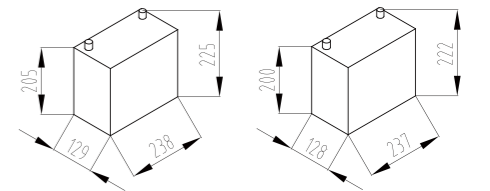
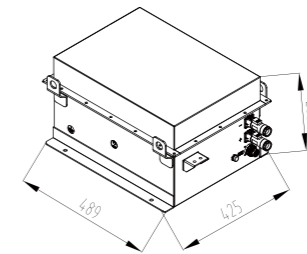
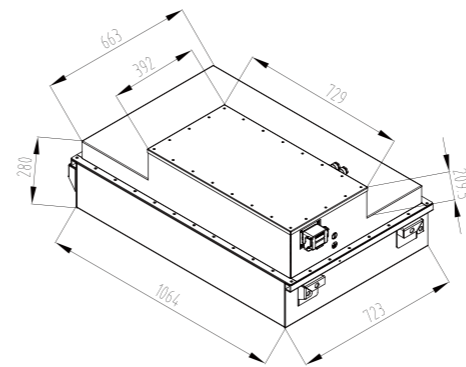
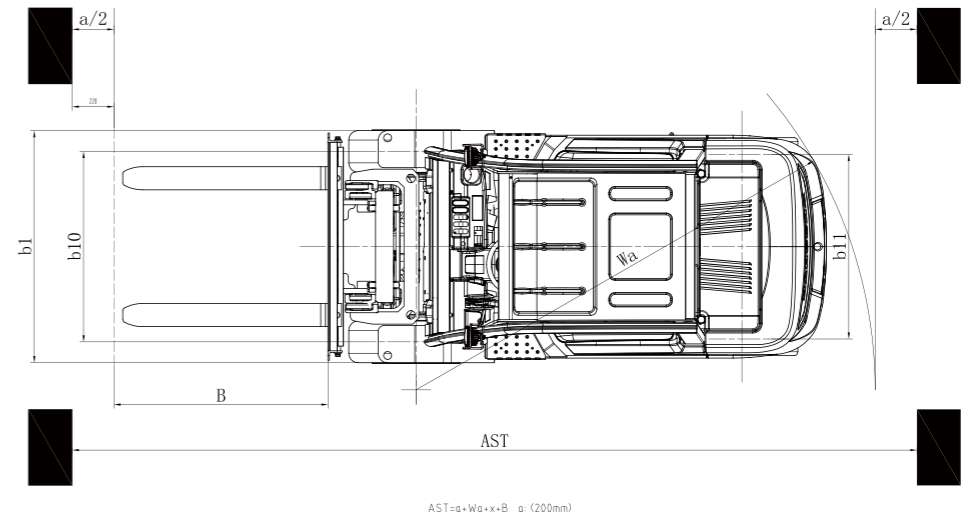
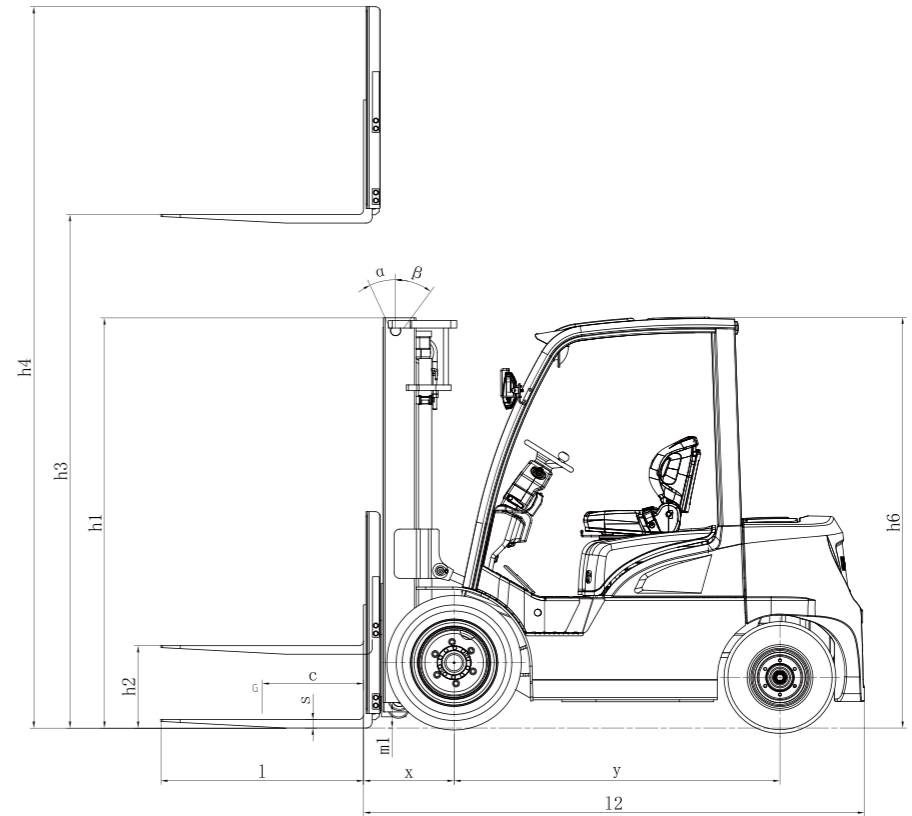

Dimension of lithium battery main box

Dimension of lithium battery secondary box

12V battery size

PERFORMANCE REDEFINED

